

---

---

## ENGINEERING SYSTEMS

---

---

DOI 10.15826/rjst.2020.1.001

УДК 697.911

*Nekrasov A. V.*Ural Federal University,  
Ekaterinburg, Russia*E-mail: anekrasov2010@gmail.com*

### MODELING OF THE VENTILATION SYSTEMS USING THE SOFTWARE EPANET

**Abstract.** The software EPANET is designed to simulate the movement of water (incompressible fluid) in hydraulic networks. When designing ventilation systems, the density of air inside them is also often considered constant. Thus, theoretically, the application can be used to simulate the operation of many types of ventilation systems. It is shown that, provided the system is represented as a graph using the proposed method of adjusting the gravitational head, EPANET can be successfully used to calculate natural and hybrid ventilation systems. At the same time, not only the required accuracy is achieved, but it is possible to verify the correctness of the design solutions for various combinations of parameters of the outside and inside air. The engineer has the opportunity to take into account the effect of wind pressure, features of the operation of supply and exhaust devices of various types and thereby significantly reduce the design time.

**Keywords:** ventilation system, aerodynamic calculation, pipeline network, EPANET

*Некрасов А. В.*Уральский федеральный университет,  
Екатеринбург, Россия*E-mail: anekrasov2010@gmail.com*

### МОДЕЛИРОВАНИЕ СИСТЕМ ВЕНТИЛЯЦИИ С ИСПОЛЬЗОВАНИЕМ ПРИЛОЖЕНИЯ EPANET

**Аннотация.** Приложение EPANET предназначено для моделирования движения воды (несжимаемой жидкости) в гидравлических сетях. При проектировании систем вентиляции плотность воздуха внутри них очень часто также считают неизменной. Таким образом, теоретически приложение может использоваться при моделировании работы систем вентиляции многих видов. Показано, что при условии представления системы в виде графа и использовании предложенного в статье метода корректировки гравитационного напора EPANET можно успешно применять для расчета систем естественной и гибридной вентиляции. При этом не только достигается необходимая точность, но появляется возможность проверить правильность конструктивных решений при различных сочетаниях параметров наружного и внутреннего воздуха. У проектировщика есть возможность учесть действие ветрового давления, особенности работы приточных и вытяжных устройств различных типов и тем самым существенно сократить время проектирования.

**Ключевые слова:** системы вентиляции, аэродинамический расчет, трубопроводная сеть, EPANET

---

© Nekrasov A. V., 2020

### Introduction

Hydraulic networks are as piping systems designed to transport incompressible fluids. Such fluids are included gases at speeds of movement that are substantially lower than the speed of the sound. Solving the problem of the distribution of flows between individual elements of a hydraulic network is an integral part of the modeling of its work.

The nonlinear system of equations describing the motion of a fluid in such a network includes two types of equations: mass balance and mechanical energy (Kirchhoff equations). The principles of building such

systems are described in detail in many books [1, 2]. Even in the case of relatively simple networks, the number of equations in this system is large and prior to the invention of computers its solution was very laborious.

Probably the first engineers who were faced with the need to solve such problems were specialists in the design and operation of water distribution networks. It is not surprising that by the end of the twentieth century, when computers became the main working tools of engineers, effective algorithms for solving systems of equations for water supply networks and a large number of programs implementing them were developed [3–8].

Another group of the hydraulic networks are ventilation systems for various purposes. The dimension of such networks is usually substantially less than water supply networks. Most often these are branching systems with known air flow rates in their individual parts. The absence of ring connections greatly simplifies the calculation, which often does not require the use of the difficult algorithms and special software for their implementation. Such tasks in the theory of hydraulic networks belong to the class of straight tasks. They are solved with the help of the overwhelming majority of the software for the designing ventilation systems.

Now engineers are increasingly forced to solve not only direct, but also more complex inverse problems for determining the actual air flow rates in various parts of ventilation system [9]. The increase in the number of floors of buildings, the use of new structural elements and materials, the erection of “warm” attics, etc. — these are just some of the reasons leading to the complication of aerodynamic calculations of ventilation systems. Insufficiently complete consideration of factors affecting the work of ventilation, leads to the fact that the system, at best, will not allow to provide high-quality ventilation of premises with some combinations of parameters of outdoor and indoor air. In the worst case, the system “overturns”, when the air from other rooms (apartments) begins to flow into rooms through ventilation channels.

In these cases, there is the task of creating a mathematical model of the system, taking into account the real conditions of its work. Only such a model after performing multivariate calculations allows us to find the optimal solution to the problems.

Further it will be shown that modeling of ventilation systems of various types can be successfully performed using software originally designed for the calculation of water supply networks. Such software now has very large capabilities that are even redundant to solve ventilation problems. It is necessary that the software allows you to portray the network on the monitor, automatically compile the Kirchhoff equations for it and solve them.

All applications for the calculation of water supply networks have these functions. Among them is the free software EPANET, which implements the gradient method for solving Kirchhoff equations (Global Gradient Algorithm, GGA) [10, 11]. A feature of this and similar algorithms is that prior to the beginning of calculations, the flows and directions of fluid flow are considered unknown. Thus, when it is used to calculate ventilation systems, it becomes possible to identify sections of the network in which the direction of the currents differs from the original design.

### Features of use EPANET

First of all, it must be borne in mind that since EPANET is designed for the calculation of the water supply networks, it uses appropriate terminology and the measure units. Traditionally, when calculating the move-

ment of the water, the losses of mechanical energy are represented as the head losses (m). The same losses in the calculating ventilation systems are represented as the pressure losses (Pa). Thus, as a unit of measurement of the head, instead of the water meters, it is necessary to use the air meters with a given temperature.

The density of water is almost constant, therefore the density of air will also have to be considered the same in all parts of the network. This means in particular that the change in air temperature during movement through windows, inlet valves and other similar elements is not taken into account. In all rooms, the temperature is also the same. This assumption does not contradict the standard methodology [12].

The most fundamental data requirement is to have an accurate representation of the network topology, which details what the elements are and how they are interconnected. If a model does not accurately describe the real-world layout, then the model will never accurately depict real-world performance, regardless of quality of remaining data.

Network topology is depicted as a graph. Graph comprised of nodes which represent the features at specific locations within the system, and links which define the relationships between nodes. The graph of the water supply network is very similar to its real-world scheme. Nodal elements are including junction nodes where pipes connect, storage tanks, reservoir nodes, etc. Elements such as pipes are classified as links.

In the case of a ventilation network, its scheme and graph do not always coincide. Fig. 1 shows the design diagram of a simple natural ventilation system and the corresponding graph. In the case of a ventilation system, there are two types of nodes: boundary and internal [13]. Boundary nodes do not really exist. These are conditional nodes through which air enters the network or is removed from it. These nodes are no. 1, 4 and 6.

In EPANET, boundary nodes are called reservoirs. Their only characteristic is the height  $z$ , counted from the reference plane common to all nodes. In water supply networks, the height of the water level into the reservoir is a geometric parameter. When calculating the ventilation systems, these heights need to be corrected, depending on the ratio of the densities of outdoor ( $\rho_{out}$ ) and indoor air ( $\rho_{int}$ ).

The principle of corrected will be explained using the simplest example (Fig. 2). Consider a system of two reservoirs connected by a pipe. The system is filled with arbitrary fluid with a density  $\rho_{int}$ . The system is surrounded by another fluid with a density  $\rho_{out}$ . The movement of the internal fluid is described by the equation:

$$\frac{p_1}{\rho_{int}g} = \frac{p_2}{\rho_{int}g} - z + \Delta h_w, \quad (1)$$

where  $p_1, p_2$  — pressure of the external fluid with a density  $\rho_{out}$  on the surface of the fluid in the reservoirs,  $g$  — gravitational acceleration constant,  $\Delta h_w$  — head loss.

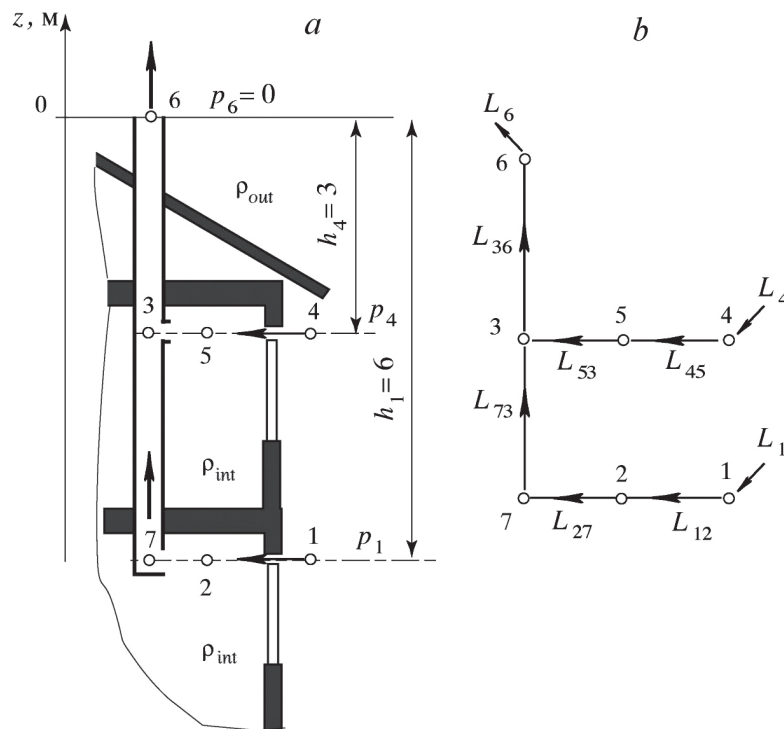

Fig. 1. Natural ventilation system (a) and its graph (b)

In turn to:

$$p_2 = p_1 + \rho_{out} g z. \tag{2}$$

Therefore gravitational head:

$$H_g = z \left( 1 - \frac{\rho_{out}}{\rho_{int}} \right) = \Delta h_w. \tag{3}$$

Into water networks  $\rho_{out} \ll \rho_{int}$  and expression in brackets close to one. Liquid moves from top to bottom.

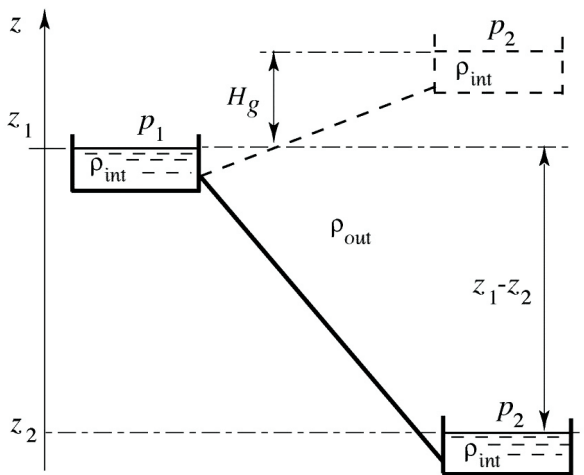

Fig. 2. Simple fluid transport system

If both fluid are air with different densities, then the expression in brackets is significantly different from one and may be negative if  $\rho_{out} > \rho_{int}$ . This situation occurs

when natural ventilation is working, when warm indoor air under the influence of the pressure of cold outside air moves from the bottom up.

Therefore in EPANET, instead of the geometric heights of the reservoirs  $z$ , it is necessary to indicate their gravitational head  $H_g$  taking into account the sign. If it is necessary to take into account the wind pressure, then its value, expressed in air meters ( $\rho_{int}$ ), must be added to the height  $H_g$  with a corresponding sign [14, 15].

The internal nodes correspond to the individual premises (room, attic, etc.), as well as to the points of confluence or separation of flows (tee, fitting, etc.).

EPANET has three types of links: pipelines, valves and pumps. Pipelines and valves are used to simulate all hydraulic resistances.

Pipe line characteristics are length  $l$ , diameter  $D$ , coefficients of minor hydraulic resistances, wall roughness. They simulate ventilation ducts, as well as those elements for which the minor loss coefficient is constant (independent of fluid flow).

The traditional method of calculating friction losses into ducts  $\Delta H_l$  is based on the use of special nomograms and correction factors to account for the surface material [16, 17]. When using EPANET, the calculation has to be carried out using the Darcy–Weisbach formula, i. e. using the friction factor  $\lambda$ .

$$\Delta H_l = \frac{8\lambda L^2}{gD^5 \pi^2}. \tag{4}$$

where  $L$  — fluid flow,  $m^3/sec$ .

Friction factor  $\lambda$  determined automatically by the formula [18]:

$$\lambda = \frac{1.325}{\left[ \ln \left( \frac{\Delta}{3.7D} + \frac{5.74}{\text{Re}^{0.9}} \right) \right]^2}, \quad (5)$$

where  $\Delta$  — equivalent sand roughness,  $\text{Re} = VD/\eta$  — Reynolds number,  $\eta$  — kinematic viscosity.

In the domestic practice of calculating pipeline systems, other formulas are used. However, in the construction of modern building ventilation systems, various inlet and exhaust devices (valves) are widely used. In such systems, the error made in determining the pressure loss in the ventilation ducts is often insignificant compared to the pressure loss into minor resistances.

Another way of modeling pipelines and any other elements of the system is the use of links — valves. This term in EPANET denotes any resistances with dependencies of head loss on flow (characteristics) in a tabular form.

The third type of the graph links are pumps in which the pressure of the fluid flow increases. In ventilation networks, their functions are performed by the fans. Flow-head characteristics of superchargers in EPANET are also set in the form of tables. The characteristics of superchargers and valves can be stored as a common library.

### Calculation example

Let us return to the considered example (see Fig. 1). It is necessary to determine the flow rate of air entering the premises through the windows at specific values of the parameters of the network elements.

Take the size of the area of the windows on each floor  $10 \text{ m}^2$  (links 1–2 and 4–5). Let us define for definiteness the dependence of the air flow rate  $L$  ( $\text{m}^3/\text{hour}$ ) on the pressure drop  $\Delta p$  (Pa), as function [19, 20]:

$$L = 6.3 \cdot (\Delta p)^{0.67}. \quad (6)$$

In the calculations, we will take into account minor pressure losses in the ventilation grilles and at the entrance to the ventilation duct with rotation of the flow (links 2–7 and 3–5). Total coefficient of minor resistance is  $\zeta = 4$ .

The ventilation ducts (links 7–3 and 3–6) have dimensions of  $120 \times 220 \text{ mm}$ . Friction factor  $\lambda = 0.034$ . This approximately corresponds to an equivalent sand roughness of 1.7 mm. When calculating the pressure loss in the link 3–6, we take into account the energy loss due to the outflow of air into the surrounding space ( $\zeta = 1$ ).

Outside and inside air temperatures are  $+5 \text{ }^\circ\text{C}$  and  $+20 \text{ }^\circ\text{C}$  respectively. In this case gravitational head  $H_g$ : for the reservoir 1 is 0.324, for the reservoir 4 is 0.162, and zero for the reservoir 6 (Fig. 3). Links 1–2 and 4–5 are modeled by valves with characteristics described by function (4), presented in the form of a table. As a result of the

solution, we obtain the fluid flows  $L_1 = 10.96 \text{ m}^3/\text{hour}$  and  $L_4 = 5.47 \text{ m}^3/\text{hour}$ .

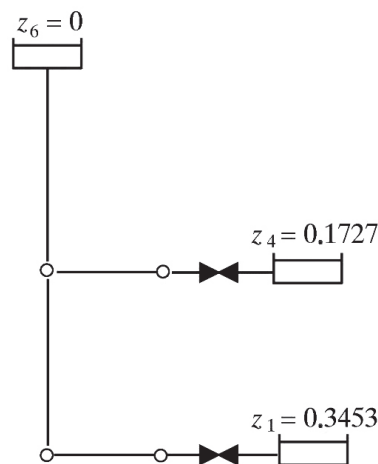

Fig. 3. Graph of the system in EPANET environment

Since when using EPANET, the characteristics of the elements have to be entered in the form of tables, rather than formulas of type (6), an interpolation error occurs. In our case, the characteristic was set as a table of 8 points in the range of  $L$  from zero to  $45 \text{ m}^3/\text{hour}$ . In this case, the resulting flows differ from the exact solution by less than one percent.

EPANET provides the ability to simulate a network not only for any combination of external and internal air parameters, but also to find solutions for improving ventilation performance. For example, in our case, an increase in air exchange can be achieved using an exhaust fan installed in link 3–6.

To determine the operating point of the exhaust fan with the required air exchange in the EPANET environment, it is sufficient to perform several consecutive calculations, gradually reducing the height  $z_6$  of the reservoir. For example, with  $z_6 = -1 \text{ m}$ , the air consumption will be:  $L_1 = 34.16 \text{ m}^3/\text{hour}$  and  $L_4 = 37.22 \text{ m}^3/\text{hour}$ . Such parameters can be achieved with the help of a fan that supplies about  $70 \text{ m}^3/\text{hour}$  at a pressure of about 12 Pa.

This technique has been tested in calculations of several types of ventilation systems, including decentralized mechanical air removal, with centralized air removal from the “warm” attic and other. In all cases, the results of calculations using EPANET are fully consistent with those obtained using the traditional method.

It should be noted once again that the application of the considered methodology is possible only in those cases when it is permissible to neglect the change in the density of air inside the ventilation network. In addition, when using EPANET all air ducts are considered round. Air ducts of the real networks very often have rectangular sections. Formal replacement of a rectangular duct with a circular one of the same area in some cases can lead to a significant error in the calculation of linear pressure losses.

## Conclusion

It is evident that almost any of the programs currently available for the calculation of water supply networks, among which there are free ones, can be used in the design of natural and hybrid ventilation systems. This not only ensures the required accuracy of the calculations, but also significantly reduces the time to complete them. This is especially important when it is necessary to simulate the operation of the system with various combinations of parameters of indoor and outdoor air, as well as when searching for the best design solutions to ensure reliable and stable operation of the ventilation system.

## References

1. Walski T. M., Chase D. V., Savic D. A., Grayman W., Beckwith S., Koelle E. *Advanced water distribution modeling and management*. Exton, Bentley Institute Press, 2007. 752 p.
2. Merenkov A. P., Hasilev V. J. *Teoriya gidravlicheskih tsepey* [Theory of hydraulic networks]. Moscow, Science Publ., 1985. 278 p. (In Russ.).
3. Na T. Y. *Computation methods in engineering boundary value problems*. New York, Academic Press, 1979. 302 p.
4. Todini E., Pilati S. A gradient algorithm for the analysis of pipe networks. In: *Computer Applications in Water Supply: vol. 1 (Systems Analysis and Simulation)*. London, John Wiley & Sons, 1988.
5. Todini E. A More Realistic Approach to the "Extended Period Simulation" of Water Distribution Networks. *Advances in Water Supply Management: Proceedings of the CCWI '03 Conference. Chapter 19*. London, 2003, pp. 173–183.
6. Todini E. On the convergence properties of the different pipe network algorithms. *Proceedings of the 8 Annual Water Distribution Systems Analysis Symposium*. Cincinnati, 2006, pp. 1–16.
7. Elhay S., Simpson A. R. Dealing with zero flows in solving the nonlinear equations for water distribution systems. *Journal of Hydraulic Engineering*, 2011, vol. 137 (10), pp. 1216–1224.
8. Simpson A. R., Elhay S. Jacobian Matrix for Solving Water Distribution System Equations with the Darcy-Weisbach Head-Loss Model. *Journal of Hydraulic Engineering*, 2011, vol. 137 (6), pp. 696–700.
9. Varapayev V. N., Kitaytseva E. H. *Matematicheskoye modelirovaniye vnutrenney aerodinamiki i teploobmena v zdaniyakh* [Mathematical modeling of the internal aerodynamics and heat transfer in buildings]. Moscow, Publishing house SGA, 2008. 338 p. (In Russ.).
10. Rossman L. A., Boulos P. F., Altman T. Discrete volume-element method for network water-quality models. *Journal of water resources planning and management*, 1996, vol. 119 (5), pp. 505–517.
11. Rossman L. A. *EPANET 2. Users Manual. Water Supply and Water Resources Division*. Cincinnati, NRMRL, 2000. 200 p.
12. Posokhin V. N. *Aerodinamika ventilyatsii* [Aerodynamics of ventilation]. Moscow, AVOK-PRESS, 2008. 209 p. (In Russ.).
13. Varapayev V. N., Kitaytseva E. H., Shabashvili I. V. Chislennoye modelirovaniye stacionarnogo vozdušno-teplovogo rezhima mnogoetazhnykh zdaniy s yestestvennoy sistemoy ventilyatsii [Numerical modeling of the stationary air-thermal mode of multi-storeyed buildings with natural system of ventilation]. *Vestnik MGSU (Monthly Journal on Construction and Architecture)*, 2011, vol. 8, pp. 122–128. (In Russ.).
14. Retter E. I. *Arkhitekturno-stroitel'naya aerodinamika* [Architectural and construction aerodynamics]. Moscow, Stroyizdat Publ., 1984. 294 p. (In Russ.).
15. *SP 20.13330.2011. Nagruzki i vozdeystviya. Aktualizirovannaya redaktsiya SNI P 2.01.07–85\** [Code of Practice 20.13330.2011. Loads and actions]. Moscow, 2011. (In Russ.).
16. *SP 60.13330.2012. Otopleniye, ventilyatsiya i konditsionirovaniye* [Code of Practice 60.13330.2012. Heating, ventilation conditioning]. Moscow, 2012. (In Russ.).
17. Bogoslovskiy V. N., Pirumov A. I., Posokhin V. N. *Spravochnik proyektirovshchika. Ventilyatsiya i konditsionirovaniye vozdukh* [The designer's Handbook. Ventilation and air conditioning]. Moscow, Stroyizdat Publ, 1992. 319 p. (In Russ.).
18. Swamee P. K., Jain A. K. Explicit equations for pipe flow problems. *Journal of hydraulic engineering*, 1976, vol. 102 (5), pp. 657–664.
19. Bogoslovskiy V. N., Titov V. P. Vozdushnyy rezhim zdaniy i uchet vozdukhopronitsaniya v raschete vozdušnogo rezhima [Air mode of buildings and calculation air permeability in heat mode]. *Paper MISI*, 1967, vol. 52, pp. 37–43. (In Russ.).
20. *GOST 26602.2–99. Bloki okonnyye i dvernyye. Metody opredeleniya vozdukho- i vodopronitsayemosti* [Interstate Standard 26602.2–99. Windows and Doors. Methods of determination of air and water transmission]. Moscow, 2000. 25 p. (In Russ.).